

DRAWING NO.
790ZSPXXX

REV
C

Manufacturing Drawing

Revision History

REV	DESCRIPTION (ECO)	DATE	APPROVED
B	REPLACE SPRING GUIDE ECN 3087	8/09/04	JRE
C	ACTIVATE 1.0/1.0 PSI OPTION, UPDATE MIL SPEC FOR "Z" SUFFIX. ECN 4447	6/03/10	L.F.

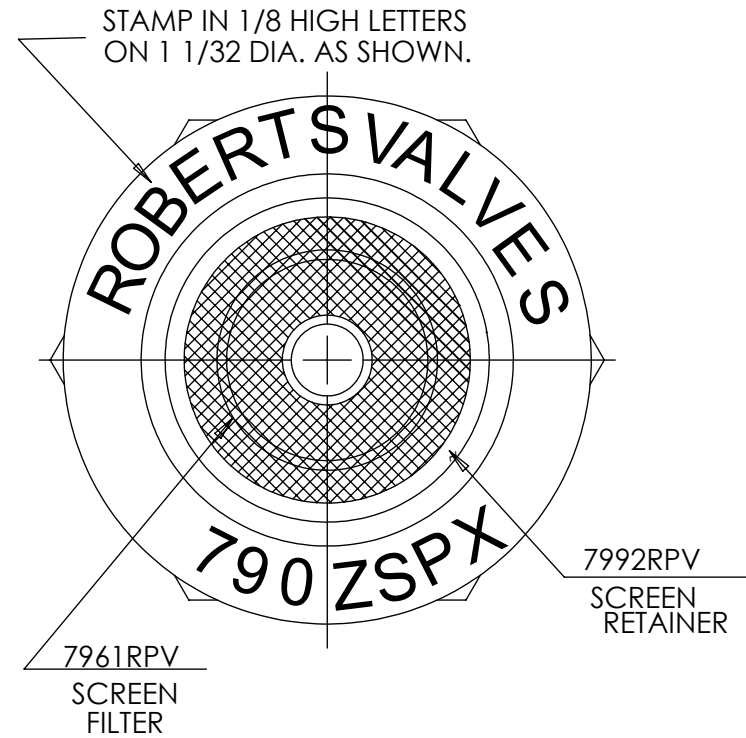
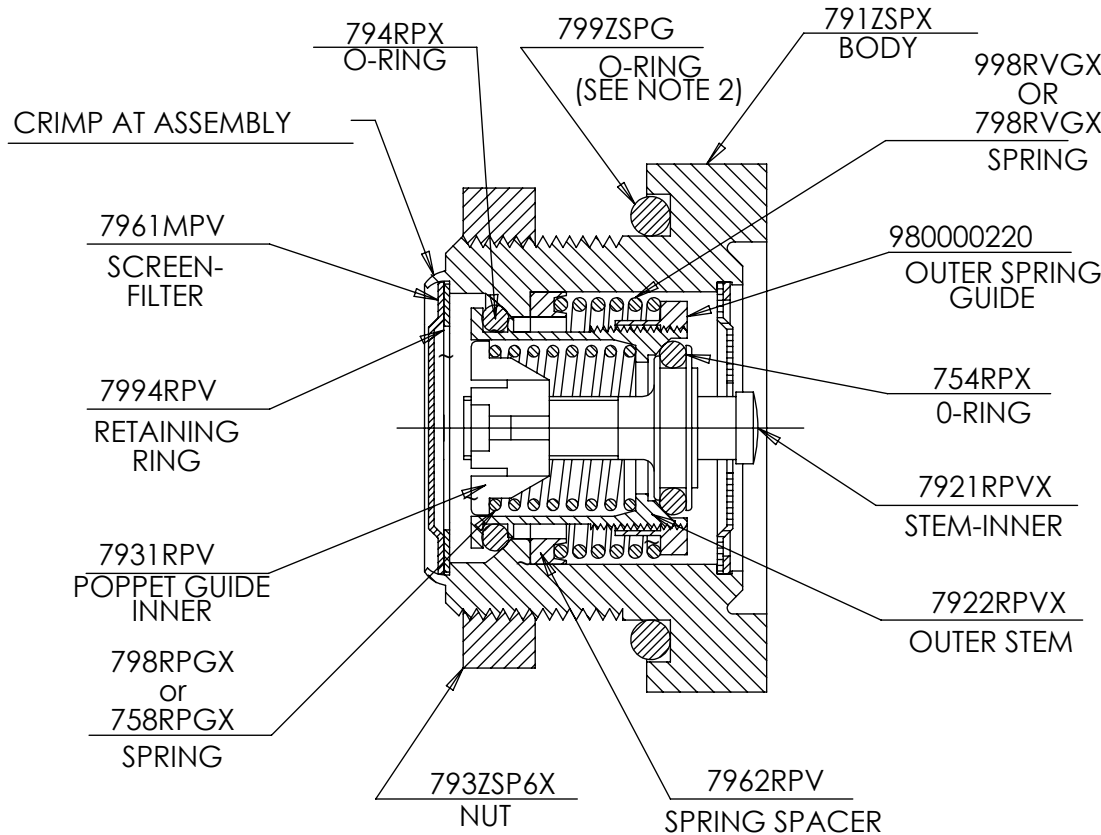

NOTES:

- FIRST SUFFIX INDICATES FINISH:
NO SUFFIX - ANODIZE PER MIL-A-8625 TYPE II, NICKEL ACETATE SEAL, BLACK DYE.
Z - CHROME CONVERSION COATING PER MIL-DTL-5541 TYPE II CLASS 3
- SECOND SUFFIX INDICATES PRESSURE IN PSI
- THIRD SUFFIX INDICATES VACUUM IN PSI
- USE WITH PARKER O-RING #2-120 N219-70 OR EQUIVALENT (BUNA-N; 70 DURO).

DRAWN BY	M.S.	DATE	11-08-01
APPROVED BY	L.F.	DATE	
MATERIAL			
FINISH			
UNLESS OTHERWISE SPECIFIED:	THIRD ANGLE PROJECTION		
<small>DIMENSIONS ARE IN INCHES TOLERANCES: ANGULAR: ± 1° TWO PLACE DECIMAL ± .01 THREE PLACE DECIMAL ± .005</small>			

 **Halkey-Roberts**

MOLDED PARTS:
GATES, PARTING LINES, AND FLASH PER QUALITY CRITERIA

PROPRIETARY AND CONFIDENTIAL

THE INFORMATION CONTAINED IN THIS DRAWING IS THE SOLE PROPERTY OF HALKEY-ROBERTS CORPORATION, ST. PETERSBURG, FL. ANY REPRODUCTION IN PART OR AS A WHOLE WITHOUT THE WRITTEN PERMISSION OF HALKEY-ROBERTS CORPORATION IS PROHIBITED.

TITLE	DUAL ACTION BREATHER VALVE		
SIZE	A	DRAWING NO.	790ZSPXXX
SCALE	2:1	SHEET	1 OF 1
DO NOT SCALE DRAWING			