

DRAWING NO. **C750RPVXX**

REV **B**

Customer Drawing

Revision History			
REV	DESCRIPTION (ECO)	DATE	APPROVED
A	NEW DRAWING ECN 3851	8/14/2008	L.F.
B	UPDATE NOTES, ADD METRIC DIM'S ECN 4240	11/17/09	AK

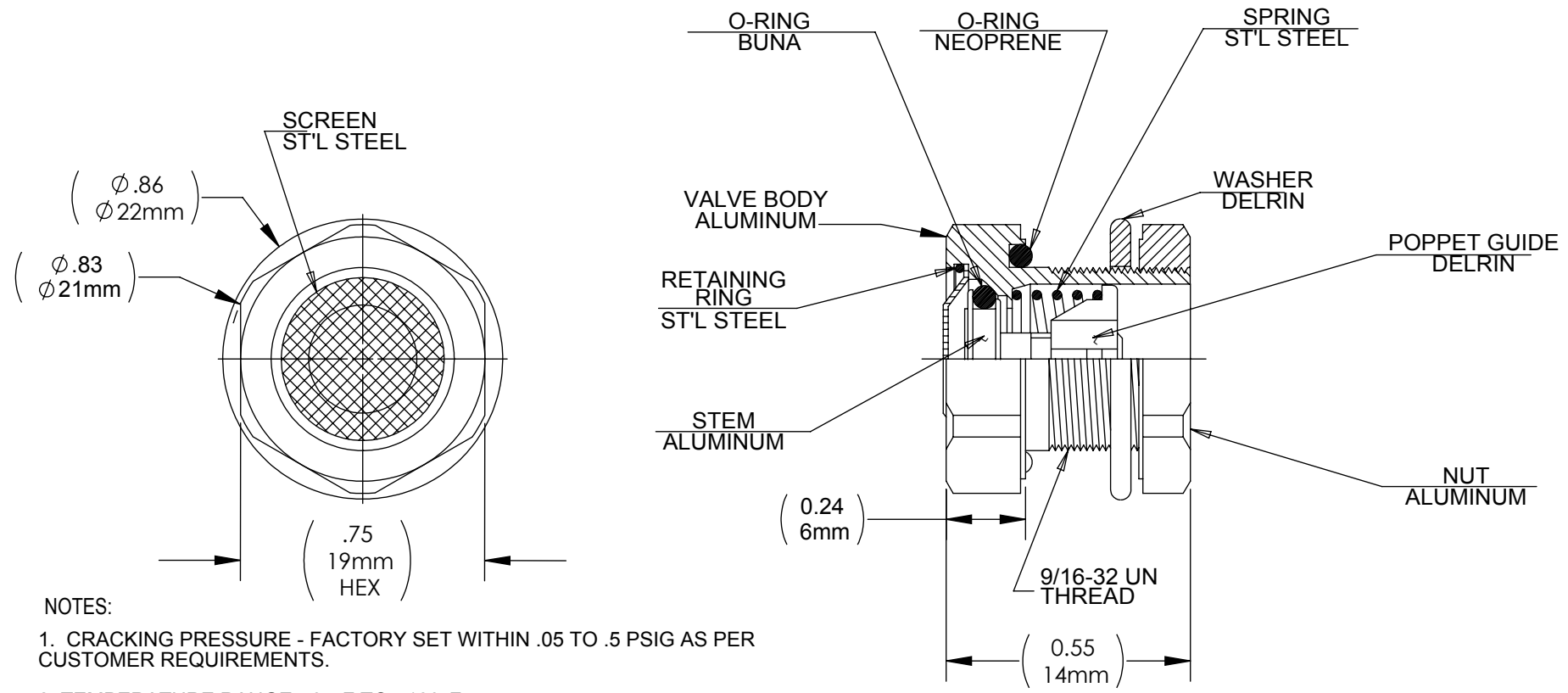

NOTES:

1. CRACKING PRESSURE - FACTORY SET WITHIN .05 TO .5 PSIG AS PER CUSTOMER REQUIREMENTS.
2. TEMPERATURE RANGE: -65°F TO +180°F.
3. CRACKING PRESSURE: ±15% OF NOMINAL; RESEAT WITHIN 20% OF NOMINAL CRACKING PRESSURE.
4. 1ST SUFFIX, "X" INDICATES CLEAR OR BLACK ANODIZE.
NO SUFFIX - CLEAR ANODIZE
BK- BLACK ANODIZE
5. 2ND SUFFIX, "X" INDICATES CRACKING PRESSURE.
(FOR EXAMPLE .05 - 5.0 PSI)
6. CRITICAL DIMENSIONS ARE CIRCLED AND SUBJECT TO INSPECTION.
7. DIMENSIONS IN PARENTHESES ARE FOR REFERENCE ONLY.
8. ALL DIMENSIONS ARE IN INCHES WITH NOMINAL DIMENSION IN METRIC BELOW.

MOLDED PARTS:
GATES, PARTING LINES, AND FLASH PER QUALITY CRITERIA

PROPRIETARY AND CONFIDENTIAL

THE INFORMATION CONTAINED IN THIS DRAWING IS THE SOLE PROPERTY OF HALKEY-ROBERTS CORPORATION ST. PETERSBURG, FL. ANY REPRODUCTION IN PART OR AS A WHOLE WITHOUT THE WRITTEN PERMISSION OF HALKEY-ROBERTS CORPORATION IS PROHIBITED.

DRAWN BY	DMC	DATE	8/14/2008
APPROVED BY	-	DATE	
MATERIAL			
FINISH	SEE NOTES		
UNLESS OTHERWISE SPECIFIED:	THIRD ANGLE PROJECTION		
<small>DIMENSIONS ARE IN INCHES TOLERANCES: ANGULAR: ± 1° TWO PLACE DECIMAL ± .01 THREE PLACE DECIMAL ± .005</small>			

Halkey-Roberts

TITLE PRESSURE RELIEF VALVE

SIZE	DRAWING NO.	REV
A	C750RPVXX	B
SCALE	DO NOT SCALE DRAWING	SHEET 1 OF 1