

DRAWING NO.
C750RVXX

REV
C

Customer Drawing

Revision History

REV	DESCRIPTION (ECO)	DATE	APPROVED
B	UPDATE FRACTIONS TO DECIMAL EQUIVALENT, FCN 3581	06/18/07	L.F.
C	ADD METRIC DIM'S, UPDATE NOTES FCN 4240	11/09/09	AK

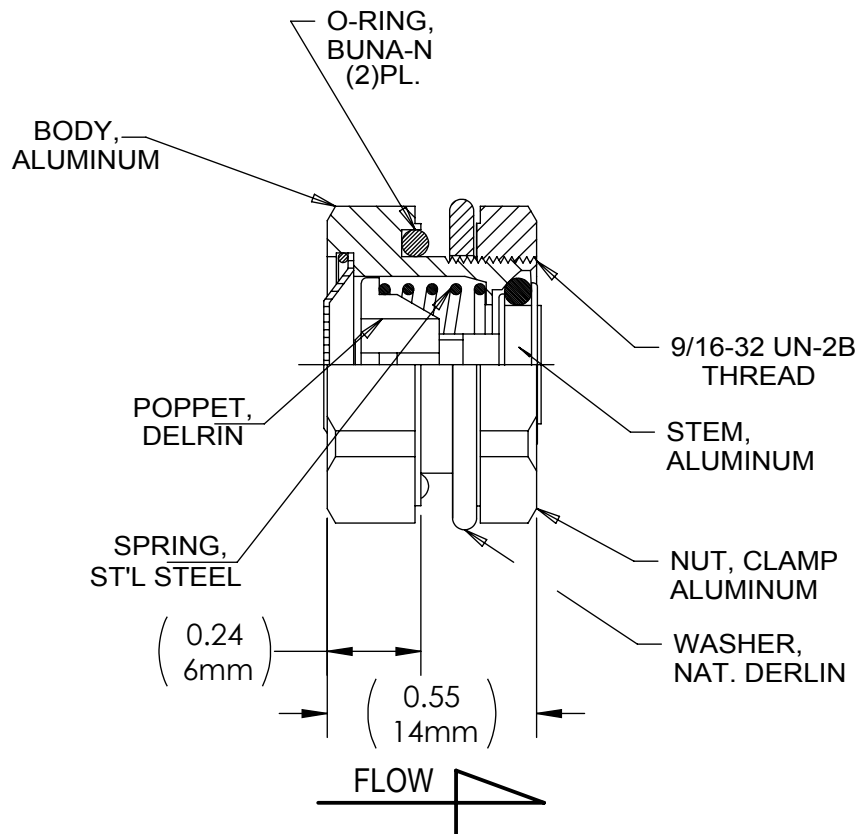
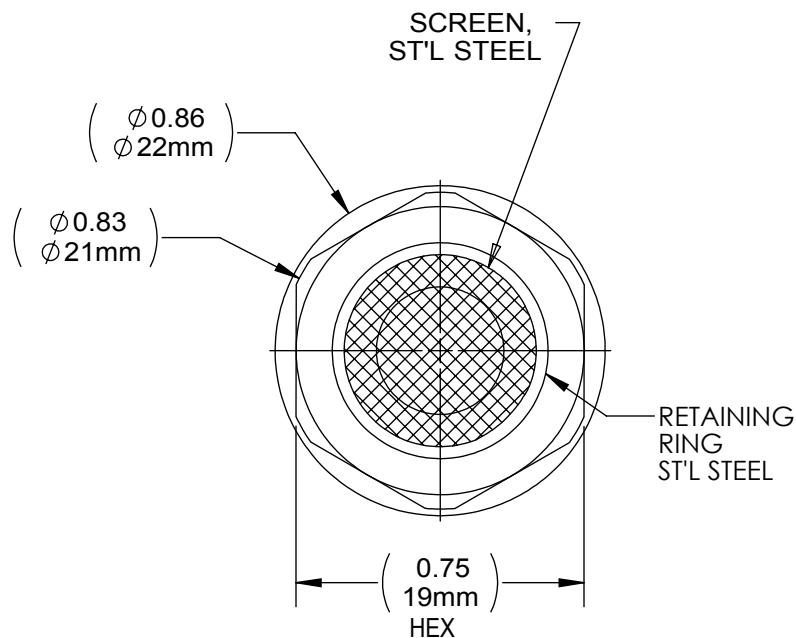

NOTES:

- FIRST SUFFIX, "X" INDICATES COLOR:
NO SUFFIX - CLEAR ANODIZE
BK - BLACK
- SECOND SUFFIX, "X" INDICATES CRACKING PRESSURE - FACTORY SET TO WITHIN 0.1 TO 20 PSIG, PER CUSTOMER REQUIREMENTS. CRACKING PRESSURE \pm 15% OF NOMINAL, RESEAT WITHIN 20% OF NOMINAL CRACKING PRESSURE.
- CRITICAL DIMENSIONS ARE CIRCLED AND SUBJECT TO INSPECTION.
- DIMENSIONS IN PARENTHESES ARE FOR REFERENCE ONLY.
- ALL DIMENSIONS ARE IN INCHES, WITH NOMINAL DIMENSION IN METRIC BELOW.
- TEMPERATURE RANGE: -65°F TO 180°F.
- WEIGHT - 0.25 OZ. (7 GRAMS).

MOLDED PARTS:
GATES, PARTING LINES, AND FLASH PER QUALITY CRITERIA

PROPRIETARY AND CONFIDENTIAL
THE INFORMATION CONTAINED IN THIS DRAWING IS THE SOLE PROPERTY OF HALKEY-ROBERTS CORPORATION, ST. PETERSBURG, FL. ANY REPRODUCTION IN PART OR AS A WHOLE WITHOUT THE WRITTEN PERMISSION OF HALKEY-ROBERTS CORPORATION IS PROHIBITED.

DRAWN BY	M.S.	DATE	06/07/99
APPROVED BY	-	DATE	-
MATERIAL	ALUMINUM, SEE NOTE		
FINISH			
UNLESS OTHERWISE SPECIFIED:	THIRD ANGLE PROJECTION		
DIMENSIONS ARE IN INCHES TOLERANCES: ANGULAR: $\pm 1^\circ$ TWO PLACE DECIMAL $\pm .01$ THREE PLACE DECIMAL $\pm .005$			

Halkey-Roberts

TITLE
RELIEF VALVE, VACUM

SIZE A	DRAWING NO. C750RVXX	REV C
SCALE 2:1	DO NOT SCALE DRAWING	SHEET 1 OF 1