

DRAWING NO.

C780RPPX

REV

B

Customer Drawing

REVISION HISTORY

REV	DESCRIPTION (ECO)	DATE	APPROVED
1	TITLE # C780RPPX REPLACES C780RPP	06/17/99	
B	UPDATE BORDER, NOTES, ADD METRIC DIM'S ECN 4240	11/10/09	AK

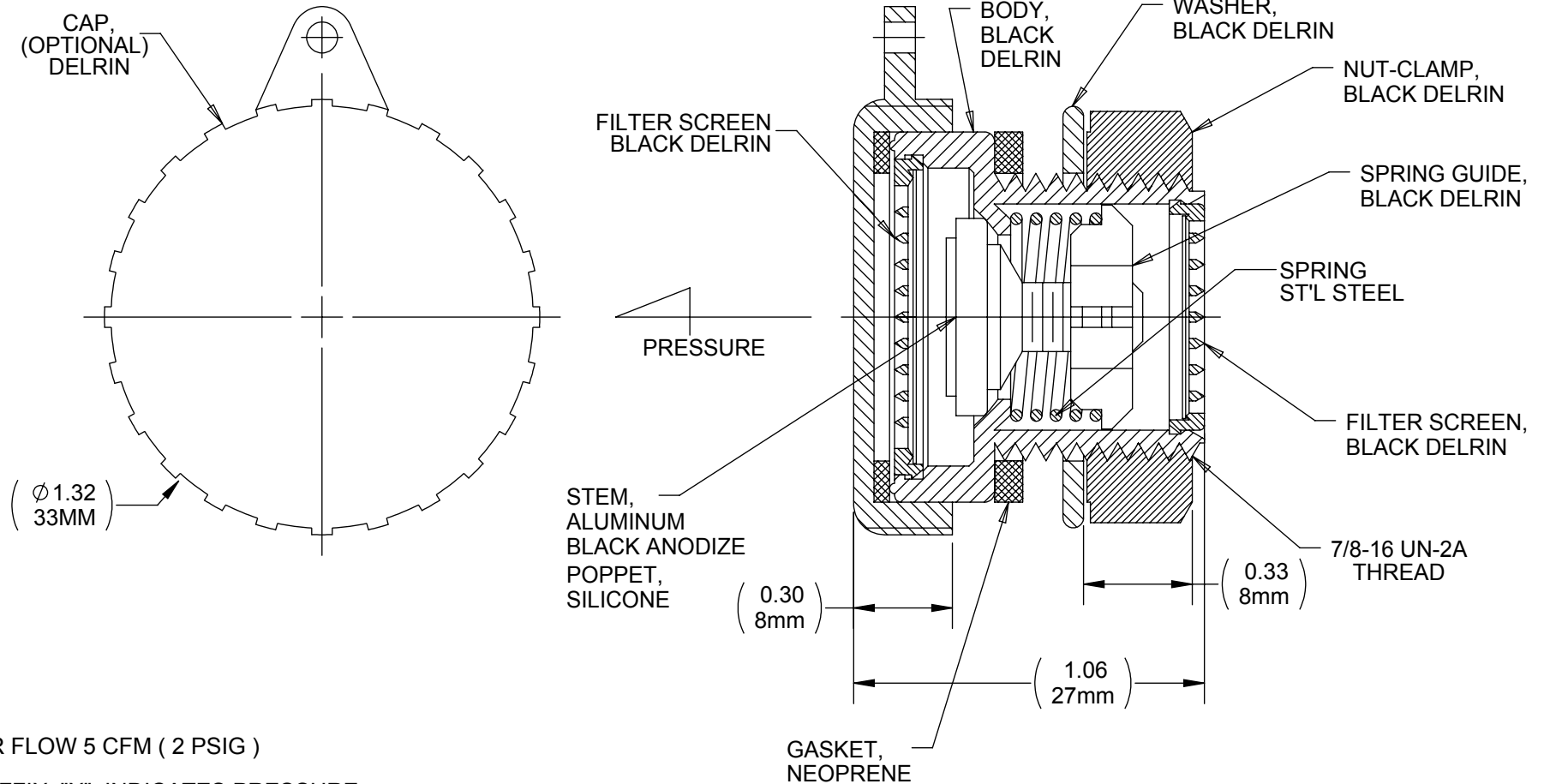

NOTES:

- AIR FLOW 5 CFM (2 PSIG)
- SUFFIX, "X" INDICATES PRESSURE
- CRITICAL DIMENSIONS ARE CIRCLED AND SUBJECT TO INSPECTION.
- DIMENSIONS IN PARENTHESES ARE FOR REFERENCE ONLY.
- ALL DIMENSIONS ARE IN INCHES WITH NOMINAL DIMENSION IN METRIC BELOW.

MOLDED PARTS:
GATES, PARTING LINES, AND FLASH PER QUALITY CRITERIA

PROPRIETARY AND CONFIDENTIAL
THE INFORMATION CONTAINED IN THIS DRAWING IS SOLE PROPERTY OF HALKEY-ROBERTS CORPORATION ST. PETERSBURG, FL. ANY REPRODUCTION IN PART OR AS A WHOLE WITHOUT THE WRITTEN PERMISSION OF HALKEY-ROBERTS CORPORATION IS PROHIBITED.

DRAWN BY	M.S.	DATE	6/17/99
APPROVED BY		DATE	
MATERIAL			
FINISH			
UNLESS OTHERWISE SPECIFIED:	THIRD ANGLE PROJECTION		
DIMENSIONS ARE IN INCHES TOLERANCES: ANGULAR: ± 1° TWO PLACE DECIMAL ± .01 THREE PLACE DECIMAL ± .005			



Halkey-Roberts

TITLE RELIEF VALVE
(PRESSURE)

SIZE	DRAWING NO.	REV
A	C780RPPX	B
SCALE	DO NOT SCALE DRAWING	SHEET
2:1		1 OF 1