

DRAWING NO.
C787RPFU

REV
A

Customer Drawing

REVISION HISTORY

REV	DESCRIPTION (ECO)	DATE	APPROVED
A	787RPFU, REPLACES 787RPFX ECN 4798	5/5/11	L.F.

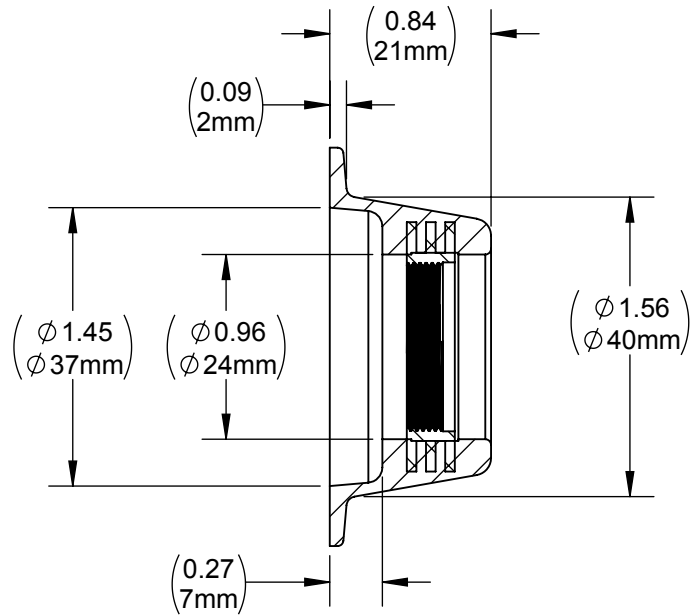

SECTION A-A

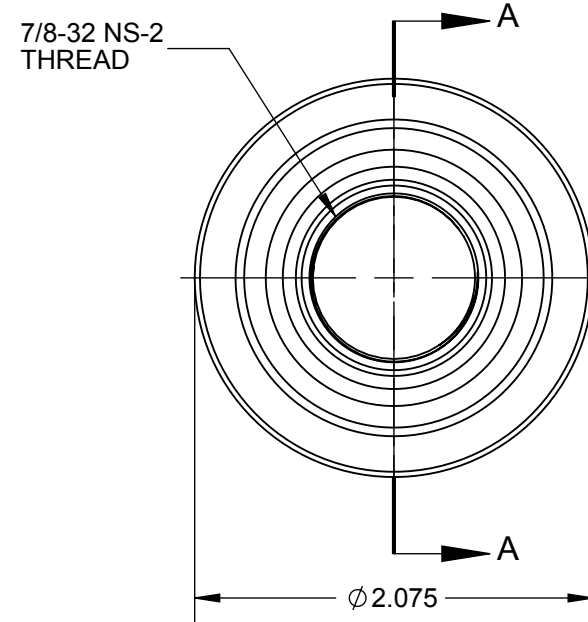

SEALING DIE	PART NO.	IFU
	D787RP	----

NOTES:

1. MATERIAL: BLACK POLYURETHANE
2. CRITICAL DIM'S ARE CIRCLED AND SUBJECT TO INSPECTION.
3. DIMENSIONS IN PARENTHESES ARE FOR REFERENCE ONLY.
4. ALL DIMENSIONS ARE IN INCHES WITH NOMINAL DIMENSION IN METRIC BELOW.

MOLDED PARTS:
GATES, PARTING LINES, AND FLASH PER QUALITY CRITERIA

PROPRIETARY AND CONFIDENTIAL
THE INFORMATION CONTAINED IN THIS DRAWING IS SOLE PROPERTY OF HALKEY-ROBERTS CORPORATION ST. PETERSBURG, FL. ANY REPRODUCTION IN PART OR AS A WHOLE WITHOUT THE WRITTEN PERMISSION OF HALKEY-ROBERTS CORPORATION IS PROHIBITED.

DRAWN BY	JHK	DATE	09-15-75
APPROVED BY		DATE	
MATERIAL			
FINISH			
UNLESS OTHERWISE SPECIFIED:	THIRD ANGLE PROJECTION		
DIMENSIONS ARE IN INCHES			
TOLERANCES:			
ANGULAR: ± 1°			
TWO PLACE DECIMAL ± .01	SIZE	DRAWING NO.	
THREE PLACE DECIMAL ± .005	A	C787RPFU	
	SCALE	DO NOT SCALE DRAWING	
	1:1	SHEET	1 OF 1

Halkey-Roberts

TITLE **FLANGE 780 VALVE**

REV **A**