

DRAWING NO.

C790RPVXX

REV

D

Customer Drawing

Revision History

REV	DESCRIPTION (ECO)	DATE	APPROVED
C	CONVERT FRACTIONS TO DECIMAL EQUIVALENT, ADD NOTE ECN 3921	1/12/09	L.F.
D	UPDATE NOTES, ADD METRIC DIM'S ECN 4240	11/10/09	AK

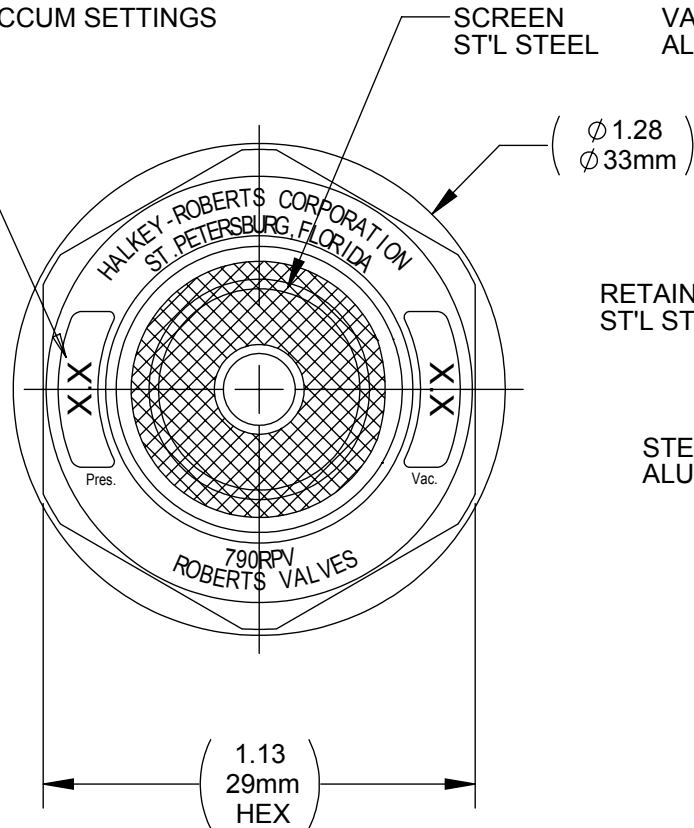
PRINT PRESSURE
& VACCUM SETTINGSVALVE BODY
ALUMINUMSCREEN
ST'L STEEL(Ø 1.28)
(Ø 33mm)RETAINING RING
ST'L STEELSTEM
ALUMINUMWASHER
DELTRIN7/8-32 UN
THREADSPRING
302 SSTPOPPET GUIDE
DELTRINORING
BUNAREAR RETAINER
DELTRINNUT
ALUMINUM(0.19)
5mm(0.19)
5mm(0.85)
21mm

NOTES:

- FIRST SUFFIX, "X" INDICATES PRESSURE.
SECOND SUFFIX, "X" INDICATES VACUUM.
- CRITICAL DIMENSIONS ARE CIRCLED AND SUBJECT TO INSPECTION.
- DIMENSIONS IN PARENTHESIS ARE REFERENCE ONLY.
- ALL DIMENSIONS ARE IN INCHES WITH NOMINAL DIMENSION BELOW IN METRIC.

MOLDED PARTS:

GATES, PARTING LINES, AND FLASH PER QUALITY CRITERIA

PROPRIETARY AND CONFIDENTIAL

THE INFORMATION CONTAINED IN THIS DRAWING IS THE SOLE PROPERTY OF HALKEY-ROBERTS CORPORATION, ST. PETERSBURG, FL. ANY REPRODUCTION IN PART OR AS A WHOLE WITHOUT THE WRITTEN PERMISSION OF HALKEY-ROBERTS CORPORATION IS PROHIBITED.

DRAWN BY M.S. DATE 06-21-99

APPROVED BY J.W. DATE

MATERIAL CLEAR ANODIZE

FINISH

UNLESS OTHERWISE SPECIFIED:

DIMENSIONS ARE IN INCHES

TOLERANCES:

ANGULAR: ± 1°

TWO PLACE DECIMAL ± .01

THREE PLACE DECIMAL ± .005

THIRD ANGLE PROJECTION

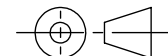

Halkey-Roberts

TITLE

DUAL ACTION BREATHER VALVE

SIZE

A

SCALE

2:1

DRAWING NO.

C790RPVXX

REV

D

SHEET

1 OF 1

DO NOT SCALE DRAWING