

DRAWING NO.

C990HBVXXX

REV

D

Customer Drawing

Revision History

REV	DESCRIPTION (ECO)	DATE	APPROVED
C	UPDATE NOTES ECR 3040	6-6-04	JRE
D	UPDATE NOTES, ADD METRIC DIMS ECN 4240	11/10/09	AK

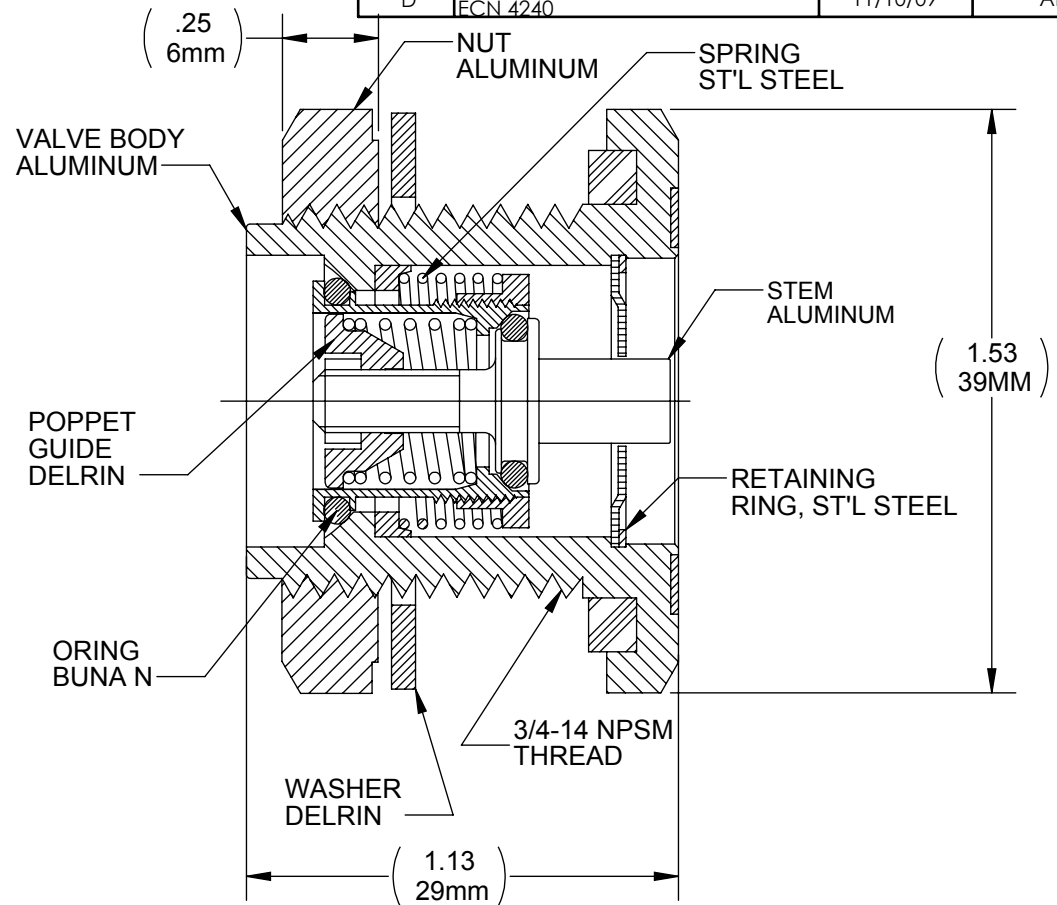
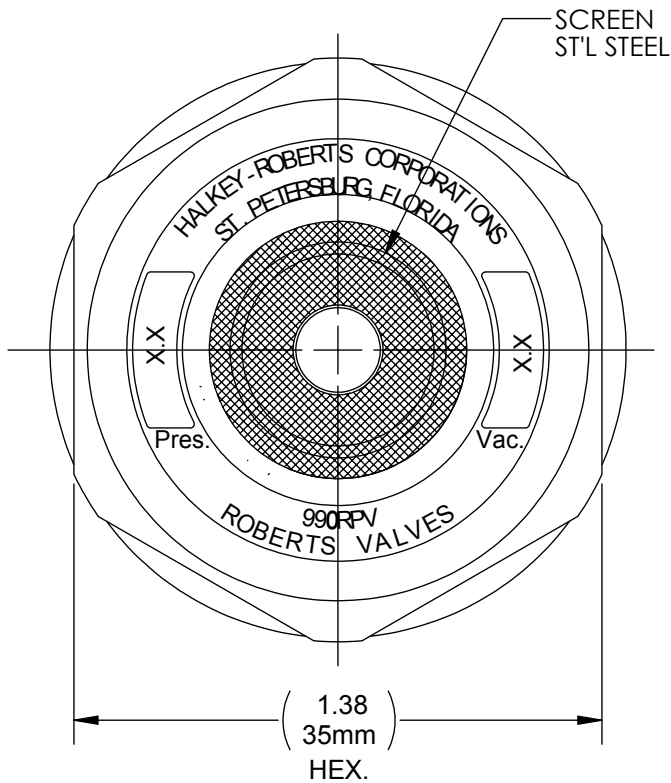

NOTES:

- FIRST SUFFIX, "X" INDICATES FINISH:
BK - BLACK
C - CLEAR
Z - CHROMATE CONVERSION
- SECOND SUFFIX, "X" INDICATES PRESSURE SETTING.
- THIRD SUFFIX, "X" INDICATES VACUUM SETTING.
- CRITICAL DIMENSIONS ARE CIRCLED AND SUBJECT TO INSPECTION.
- DIMENSIONS IN PARENTHESES ARE FOR REFERENCE ONLY.
- ALL DIMENSIONS ARE IN INCHES WITH THE NOMINAL DIMENSION IN METRIC BELOW.

MOLDED PARTS:

GATES, PARTING LINES, AND FLASH PER QUALITY CRITERIA

PROPRIETARY AND CONFIDENTIAL

THE INFORMATION CONTAINED IN THIS DRAWING IS THE SOLE PROPERTY OF HALKEY-ROBERTS CORPORATION ST. PETERSBURG, FL. ANY REPRODUCTION IN PART OR AS A WHOLE WITHOUT THE WRITTEN PERMISSION OF HALKEY-ROBERTS CORPORATION IS PROHIBITED.

DRAWN BY M.S. DATE 03-3-99

APPROVED BY J.W. DATE 03-3-99

MATERIAL

FINISH SEE NOTES

UNLESS OTHERWISE SPECIFIED:

DIMENSIONS ARE IN INCHES

TOLERANCES:

ANGULAR: ± 1°

TWO PLACE DECIMAL ± .01

THREE PLACE DECIMAL ± .005

THIRD ANGLE PROJECTION

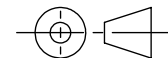

Halkey-Roberts

TITLE

DUAL ACTION BREATHER VALVE

SIZE

A

DRAWING NO.

C990HBVXXX

REV

D

SCALE

1:1

DO NOT SCALE DRAWING

SHEET

1 OF 1